



Job _____ Item No. _____

Star-Max® Electric Hot Plate

□501FF □502FF



502FF

DESCRIPTION

Star-Max® electric hot plates are designed to be a reliable, versatile, and maintenance-free solution for almost any menu item. These units come in a wide variety of sizes and styles to fit any operation and provide the long-lasting solution you need for warming, cooking, and sauteing.

SPECIFICATIONS

Star-Max® electric hot plates will be constructed of aluminized steel with a stainless top and front bullnose. Units will be equipped with infinite control[s], pilot light[s], and sealed cast iron elements. Units will come with a junction box on the rear, ready to hard-wire or have a plug attached. The units will be designed to operate at 208 V/240 V. Units will be supplied with 4-inch (102 mm) tall legs.

WARRANTY

These units come with a two [2] year warranty for parts and labor.

FEATURES

- Sealed cast iron french top[s] for fast, even heating
- Independent temperature control for each burner
- Double-wall construction, enclosed bottom, and solid top reduce heat loss and provide a more comfortable work zone
- Compact design to fit almost any operation
- Heavy-duty metal knobs

CERTIFICATIONS



STAR MANUFACTURING INTERNATIONAL INC.
10 Sunnen Drive • Saint Louis, Missouri 63143
Telephone 800 264 7827 • Fax 314 781 5445
www.star-mfg.com



Printed in the U.S.A. • 2M-Z21737 • Rev - • 10.2016
Specifications are subject to change without notice and are not intended for installation purposes.



Star-Max[®] Electric Hot Plate

□501FF □502FF

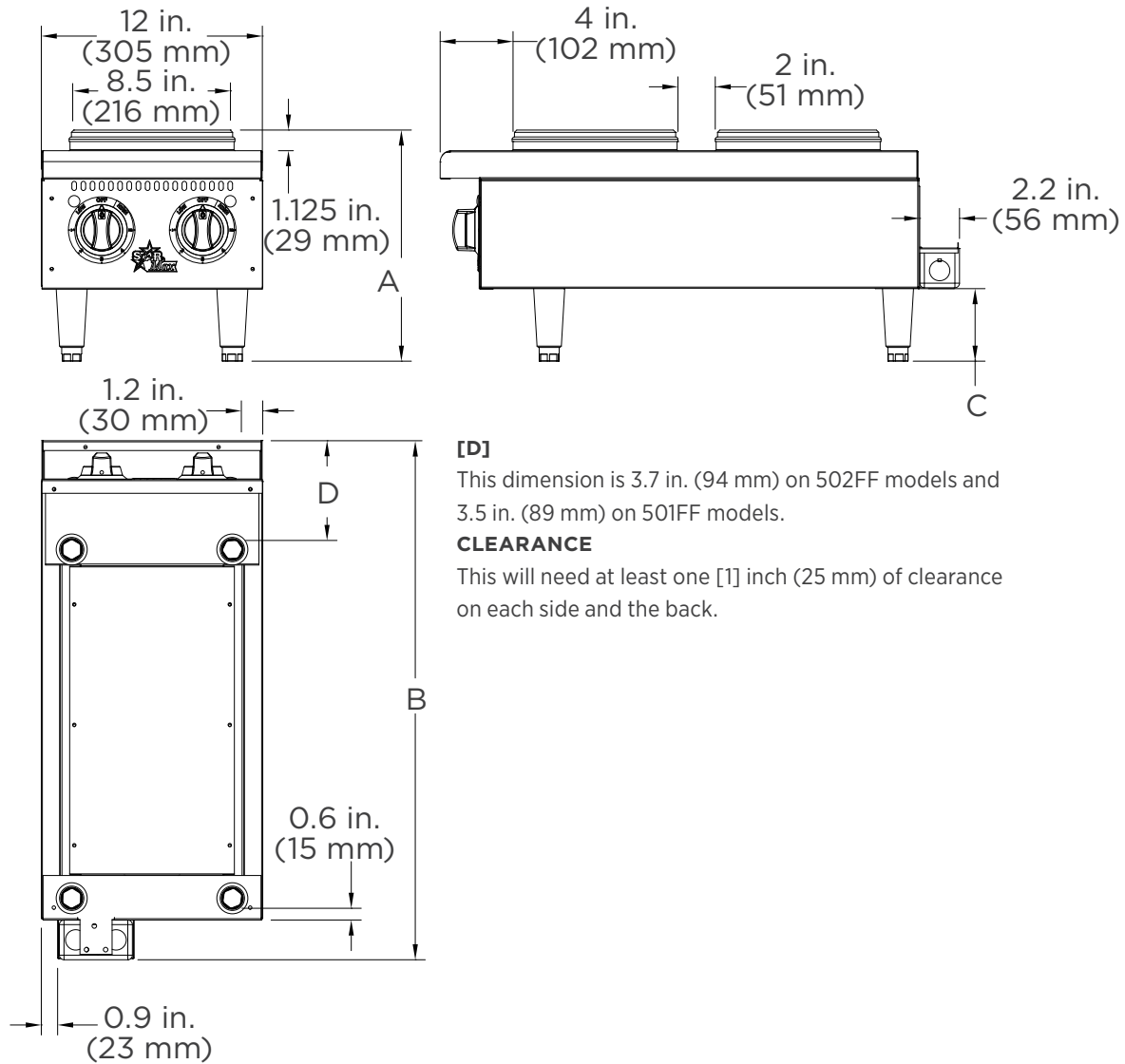

MODEL	HEIGHT [A] in. (mm)	WIDTH in. (mm)	DEPTH [B] in. (mm)	LEG HEIGHT [C] in. (mm)	VOLTS	WATTS	AMPS	APPROX. SHIP WEIGHT	APPROX. WEIGHT INSTALLED
501FF	11.1 (282)	12 (305)	17.3 (439)	2.5 (64)	208/ 240	1,950/ 2,600	9.4/ 10.8	35 lb. (15.9 kg)	25 lb. (11.3 kg)
502FF	12.6 (320)	12 (305)	28.2 (716)	4 (102)	208/ 240	3,900/ 5,200	18.75/ 21.7	45 lb. (20.4 kg)	35 lb. (15.9 kg)

Due to periodic changes in designs, methods, procedures, policies and regulations, the specifications contained in this sheet are subject to change without notice. While Star Manufacturing exercises good faith efforts to provide information that is accurate, we are not responsible for errors or omissions in information provided or conclusions reached as a result of using the specifications. By using the information provided, the user assumes all risks in connection with such use.



STAR MANUFACTURING INTERNATIONAL INC.

10 Sunnen Drive • Saint Louis, Missouri 63143

Telephone 800 264 7827 • Fax 314 781 5445

www.star-mfg.com

Printed in the U.S.A. • 2M-Z21737 • Rev - • 10.2016
Please refer to the owner's manual for information regarding installation or use.