



# CHEMICAL SANITIZING UNDERCOUNTER DISHWASHER / GLASSWASHER

## GL-X



### CMA MODEL: GL-X

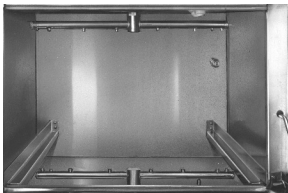

Upper and lower rotating wash arms guarantee excellent results.



"Works-in-a-drawer." All electrical components are attached to a sliding drawer for easy access and service.

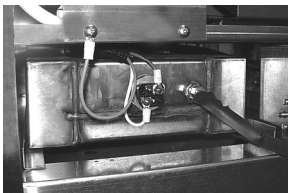

Built-In Hot Water Assurance System provides hot water every cycle.

### FEATURES

- 30 racks per hour.
- Large 11-1/4" door opening.
- Economical to operate. Uses only 1.7 gallons of water per cycle.
- All stainless steel construction assures long life and years of trouble free operation.
- Unique spray arm system features upper and lower stainless steel wash arms with reinforced end caps.
- Built-in chemical pumps and deliming system assures proper chemical usage.
- Convenient to service "Works-in-a-drawer". All electrical components are attached to a sliding drawer for easy access and service.
- Instant start for simple operation.
- Pumped drain allows for flexible installations. No floor drain required.
- Wash tank sustainer heater keeps water at proper temperature between loads.
- Stainless Steel Legs 4" (set of 4).
- Uses standard 19-3/4"-19-3/4" racks.
- Dishmachine comes with one 16 compartment rack.

### AVAILABLE OPTIONS

- Low Chemical Alarm
- Drain Board
- CMA TEMP-SURE

**CMA  
MIZER®**  
Registered Trademark





**GL-X**  
Chemical Sanitizing  
Dishwasher / Glasswasher

**WARNINGS:**

- Electrical and Plumbing connections must be made by a qualified service company who will comply with all available Federal, State, and Local Health, Electrical, Plumbing and Safety codes.
- CMA recommends utilizing a water softening system to maintain water hardness measurements of 3.5 gpg (grains per gallon) or less. This will assure maximum results and optimum operation of the dishmachine.

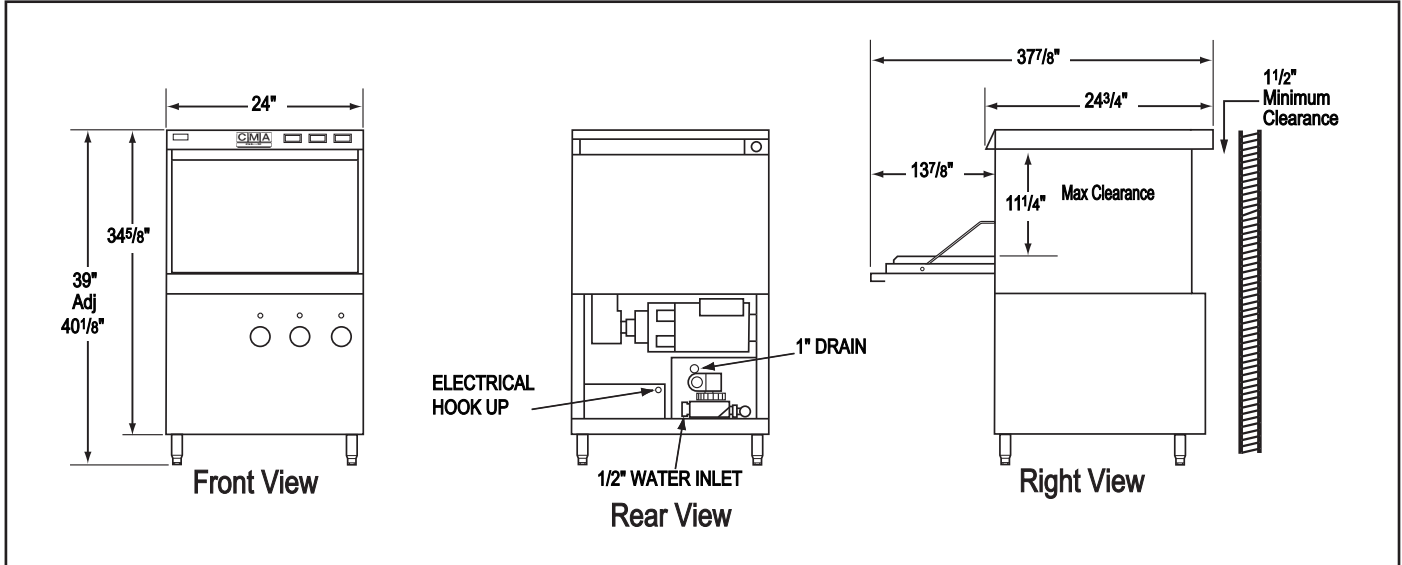

**Specifications:**

| MODEL GL-X  | USA                              | METRIC   | USA                                      | METRIC                                      |
|---|----------------------------------|--|--|---|
| <b>OPERATING CAPACITY</b><br>RACKS PER HOUR   | 30                               | 30   |  |   |
| <b>OPERATING CYCLE</b><br>WASH TIME-SEC<br>RINSE TIME-SEC<br>DWELL/TIME-SEC<br>TOTAL CYCLE TIME | 58<br>32<br>30<br>120            | 58<br>32<br>30<br>120                          |  |   |
| WASH TANK CAPACITY  | 1.7 GAL.                         | (6.45 L)                                       |  |   |
| WASH PUMP CAPACITY  | 35 GPM                           | (132 LPM)                                      |  |   |
| <b>MINIMUM TEMPERATURE REQUIRED</b><br>WASH TEMP.   | 120°F                            | (50°C)   |  |   |
| <b>WATER CONSUMPTION</b><br>PER RACK<br>PER HOUR<br>WATER INLET<br>DRAIN                        | 1.7 GAL.<br>51 GPH<br>1/2"<br>1" | (6.45 L)<br>(193 LPH)<br>(1.27 cm)<br>(2.54cm) |  |   |
| <b>WASH PUMP MOTOR HP</b>   |                                  |  | 1  | 1   |
| <b>DIMENSIONS</b><br>DEPTH<br>WIDTH<br>HEIGHT<br>MAXIMUM CLEARANCE FOR GLASSWARE                |                                  |  | 24-3/4"<br>24"<br>39"-40-1/8"<br>11-1/4" | (63cm)<br>(61cm)<br>(99-102cm)<br>(28.57cm) |
| <b>STANDARD DISHRACK</b><br>DIMENSIONS  |                                  |  | 1<br>20" x 20"                           | 1<br>(50.8 X 50.8cm)                        |
| <b>ELECTRICAL RATING</b>  |                                  |  | <b>VOLTS</b><br>115                      | <b>AMPS</b><br>16                           |
| <b>APPROXIMATE SHIPPING WEIGHT</b><br><b>SHIPPING DIMENSIONS</b>                                |                                  |  | 202#<br>PALLET & BOX @ 29" X 28" X 42"   | (92kg)                                      |

**Summary Specifications: Model GL-X**

The GL-X dishmachine is a low temperature undercounter dishmachine designed to produce sparkling clean all wares utilizing our unique Hot Water Assurance System. The GL-X is easy to use, fast and efficient, while conserving water, energy and chemicals. Built-in sustainer heater provides continuous 130°F hot water every cycle. The GL-X is constructed entirely of stainless steel and is equipped with an integrated chemical delivery system. The GL-X incorporates a pump purging system that improves results by eliminating soil and chemical carryover during rinse cycle.

**Advisory:** CMA does NOT endorse "Tankless On-Demand" water heaters for use on CMA Dishmachine products. CMA DOES endorse, and highly recom-mends, the standard "tank" style water heaters, sized properly to handle each particular facility with their water heating requirements.



CMA Dishmachines 17707 Valley View Ave; Cerritos, CA 90703 • 800-854-6417 • 714-898-8781 • Fax: 714-895-2141 • www.cmadishmachines.com

CMA reserves the right to modify specifications or discontinue models without prior notification.

© 09-2024 CMA, Inc.

